

LEGAL NOTICE:

This publication was originally based in part on material obtained from Puget Sound Power & Light Co. © 1996 through Alexander Publications, although the same has been substantially modified and revised herein. All rights reserved.

This publication is intended solely for the internal use of Flathead Electric Cooperative, Inc. (FEC) (which includes distribution to its members), and shall not be copied or reproduced, in whole or in part. FEC DISCLAIMS ANY AND ALL WARRANTIES, EXPRESS OR IMPLIED, REGARDING THE CONTENTS OF THIS PUBLICATION INCLUDING, WITHOUT LIMITATION, ANY IMPLIED WARRANTY OF MERCHANTABILITY OR FITNESS. FURTHER, FEC DOES NOT MAKE ANY WARRANTY WITH RESPECT TO THE ACCURACY, COMPLETENESS OR USEFULNESS OF ANY INFORMATION CONTAINED IN THIS PUBLICATION OR THAT THIS PUBLICATION IS FREE OF ERRORS, DEFECTS AND DEFICIENCIES OR THAT IT CONFORMS TO ANY APPLICABLE LAW, STANDARD OR PRACTICE. FEC SHALL NOT BE LIABLE WITH RESPECT TO ANY USE OF OR RELIANCE UPON ANY DATA OR INFORMATION CONTAINED OR REFERENCED IN THIS PUBLICATION.

CONTENTS

Overview of Hookup Procedures	2	Underground Service	
Welcome to Flathead Electric	3	General Requirements	12
Getting Started	3	Service Equipment Installation Requirements	12
Requesting Service	3	Service Size Conduit Requirements	12
		Items Owned and Installed by FEC	13
		Items Owned and Installed by Member	13
Introduction			
Overhead and Underground Service	4	Manufactured Homes	
Contacting Other Utilities	5	General Requirements	14
Service Ratings	5	Meter Pedestals	14
Meter Location	5	Custom Built Meter Pedestals	14
Removing and Installing Meters	5	Factory Built Meter Pedestals	15
Outbuildings	5	100/200 Amp Service	15
Temporary Service	5	320 Amp Service	16
Inspections and Codes	5	Services 400 Amps and Above	16
Emergency or Standby Generators	5	Grounding Requirements	16
		Clearance Requirements	16
Overhead Service		Outbuildings	17
General Requirements	6	Underground Locates	17
Getting Started	6	Trench	17
Service Mast Requirements	6	Conduits	17
Height Requirements	6	Vaults	18
Additional Mast Supports	8		
Service Equipment Installation Requirements	9	Contact Information	19
Manufactured Homes	9		
Meter Poles	10	Glossary of Terms	19
100/200 Amp Overhead Service Meter Base Requirements	10		
320 Amp Overhead Service Meter Base Requirements	10	Appendix (Photos)	20
Services 400 Amps and Above	11		
Clearances from Building			
Openings and Gas Meters	11		
Clearance Requirements	11		
Outbuildings	11		

OVERVIEW OF HOOKUP PROCEDURES

The following is a general outline of how you get a new electrical service for a single-family residential structure. This outline assumes that Flathead Electric Cooperative (FEC) has existing power facilities near your site. If power is not readily available, FEC will need to engineer a primary line extension to your project. If you have any questions, please contact the FEC Staking Department.

Your Responsibilities to Obtain Electrical Service

1. Determine if you want overhead or underground service (see page 4)
2. Determine the size of service you want (200 amp, 320 amp, etc.) (see page 10)
3. Apply for an Electrical Permit
4. Contact the FEC Staking Department
5. Notify other utilities of your project (see page 5)
6. Install your service entrance equipment
7. Call “U-Dig” before you dig (see page 19)
8. Provide trench and conduit for underground services
9. Provide a clear path for your overhead service line (see page 6)
10. Call FEC Staking Department when you are ready for us to install the service wire

This illustrated handbook clearly defines everyone’s responsibilities for installing new commercial or temporary electric service. Following its guidelines will eliminate extra phone calls and visits to the job site, saving money for electricians, property owners, developers, and FEC.

Preparations for each type of new service are presented separately. For details, simply turn to the chapter which describes your situation. Information has been repeated wherever necessary, making each chapter complete and independent.

Flathead Electric Cooperative’s Responsibilities

1. Install and connect the service line to your underground meter base or overhead mast wiring.
2. Install a meter.
3. Energize your system.

Scheduling

If only service wire and a meter installation are required, services are typically energized within a week after you have completed the appropriate “Your Responsibilities” section as previously stated. If additional work is required, it may take longer.

Service Charges

Charges vary due to the type of service you are requesting and the type of system we have in your area. Please contact the FEC Staking Department for more information.

WELCOME TO FLATHEAD ELECTRIC COOPERATIVE, INC.

This handbook provides you with Flathead Electric Cooperative's (FEC's) requirements for new electric service for permanent single-family residential structures. Also included, is helpful information from the National Electrical Code (NEC), and the requirements for service to outbuildings such as barns, shops, pump houses, garages, etc. This handbook contains information that will help you to answer questions like:

- Where should I install the meter base?
- Where will the service route be?
- How tall does my service mast have to be?
- What are the size requirements for the meter base?
- What do I have to do for an underground service?
- How do I install my meter base?
- How do I get the existing underground utilities located before I dig?

The answers to these and many other questions are here. If you have any additional questions, please call our office. A directory of numbers can be found on page 19.

Information regarding the installation of permanent service for multifamily and nonresidential services such as commercial buildings, condominium complexes, apartment buildings, and mobile home parks, can be found in FEC's *Electric Service Requirements Handbook*.

To establish an account, to get answers to general billing questions, to get answers to technical questions and to have a service hooked up, please contact FEC's Staking Department.

GETTING STARTED

Installing new electrical service to a home is a joint project between you and FEC. FEC is responsible for installing the service lines to bring power to the residence, and for installing a meter in the meter base. You are responsible for:

- Determining if you want overhead or underground service.
- Installing a temporary/permanent meter base.
- Wiring from the meter base or pedestal to your residence.
- All electrical wiring in your residence.
- Obtaining permits and inspections.
- Maintaining your equipment.
- Keeping the meter base visible and accessible.
- Providing and maintaining a clear path for the overhead service lines.
- Providing trench and conduit for underground service lines.

REQUESTING SERVICE

Prior to contacting FEC, we would request that you be prepared to answer the following questions:

- What is the service for (home, barn, shop, etc.)?
- How many square feet in your residence?
- Will you have electric heat or gas?
- Will you have a heat pump, furnace or zonal heating?
- Will you have gas or electric water heat?
- What ampere rating will your service require?
- When will you be ready for service?
- Would you like overhead or underground service?
- If overhead, is it allowed by local ordinances and covenants?
- Is the existing power system in the area overhead or underground?

If the existing system is overhead and the new service is to be overhead:

- Is the new meter location less than 200 feet from the nearest power pole?
- Will your service line cross property owned by anyone else?

If the existing power system is overhead and the new service is to be underground:

- Is the new meter location less than 200 feet from the nearest power pole?

If the existing system is underground (only underground service is available in this case):

- Is the new meter location less than 200 feet from the nearest utility transformer?

To start the process of installing a new service, you will need to contact FEC and ask to speak with the Staking Department. FEC requires a non-refundable engineering deposit for all new services. Contact the Staking Department for deposit pricing. The deposit will be applied to the cost of your job should you decide to proceed.

The Staking Department will discuss the process for getting your service installed, answer any questions you may have and set an initial appointment for a staking engineer to visit your site. They will also request general billing information, discuss fees and request the address for your new service. **This address must be supplied and posted at your job site.** Remember, it is your responsibility to obtain the new address from your local county plat room. A directory of numbers can be found on page 19.

OVERHEAD OR UNDERGROUND SERVICE

Two types of electrical service are available: Overhead and underground. Underground service is available to everyone. Overhead service is available if FEC's system is overhead, and if local ordinances allow it. It is your responsibility to be aware of any applicable local codes and ordinances. You can determine if FEC's system is overhead or underground by checking for our facilities along the road. If the power system is overhead, a series of poles similar to Figure 1-1 will be visible. If the power system is underground, there will be items like those in Figures 1-2 through 1-5. If our system is overhead, and you wish to have an overhead service installed, the requirements for overhead services can be found in the Overhead Services section of this book starting on page 6. If the system is overhead, but you wish to have an underground service, those requirements are in the Underground Services section of this book starting on page 12.

If FEC's system is underground, your only option is an underground service. Refer to the Underground Services section of this book for those requirements. For help determining which type system is in your area, call our office and ask to speak to someone in the Staking Department.



Figure 1-1. Pole with transformer.



Figure 1-2. Padmount transformer.



Figure 1-3. Service stub out.



Figure 1-4. Secondary hand hole.



Figure 1-5. Secondary pedestal.

CONTACTING OTHER UTILITIES

New construction typically involves the installation of water, sewer, telephone, cable TV and natural gas lines, as well as power cables. It is your responsibility to notify each of the utilities that you wish to provide service to your home. You should get the name and phone number for a contact at each utility and let each of them know which other utilities will be providing new service.

SERVICE RATINGS AVAILABLE

FEC offers several sizes of service for single family residential structures, and for outbuildings. (See “Outbuildings” below) The size of service you need depends upon the size of the home and the power requirements of the equipment you will be installing. FEC **cannot** determine your power requirements.

VOLTAGE AMPERE RATING TYPICAL USE

120/240 100/200 Amps ~ Small and medium sized homes
(most common service size)

120/240 320 Amps ~ Large homes

120/240 Over 320 Amps ~ Very large homes

METER LOCATION

You must install your meter base where it will be accessible to FEC at all times. All locations are subject to approval by a FEC representative. FEC requires putting the meter base on the quadrant of your house closest to the FEC transformer. The requirements for properly locating your meter base are:

- It must be outside
- It must be located in an area that is not subject to being fenced, such as patios, decks, porches, backyards
- It must be located on a structure that is owned by you or on a meter pole owned by FEC.

The reasons for these requirements are:

- So FEC meter personal can obtain periodic meter readings in a cost effective manner.
- So FEC can efficiently maintain the meter.
- So our employees can stay out of your backyard.
- If there is a fire or other disaster, we can disconnect your service.

It should be pointed out that FEC will not accept recessed, semi-flush or flush mounted meter base installations. Also all meter base installations must provide protection from ice, snow and debris unloading from the roof.

REMOVING AND INSTALLING METERS

Only authorized and qualified FEC personnel shall remove and install meters. Qualified electricians with prior approval from FEC may remove a meter to disconnect the service under abnormal or emergency conditions. Note: With some types of meter bases removal of the meter does not de-energize the customer’s system. The purpose of seals by FEC on meters and associated service equipment is to prevent injury and/or tampering.

OUTBUILDINGS

An outbuilding is a stand-alone structure which is located on residential property and is not a living space. Typical outbuildings are

barns, pump houses, garages, shops, storage sheds, etc. If you wish to install a separate service to your outbuilding, you are required to provide a clear path/trench and conduit to our equipment, a properly located meter base, and service equipment as required in the NEC. It will be your responsibility to install the meter base and service equipment. Depending on the size of service equipment and the type of facility that is being served, the meter base may be required to have provisions for or have manual bypass blocks.

TEMPORARY SERVICE

Most service installations can be coordinated to provide your permanent service early on in the construction process. This will eliminate the need for a temporary service. This in turn eliminates an additional visit to your construction site and eliminates additional costs to you. However, if temporary service is required for your project, FEC will connect it under the following conditions:

- Temporary meter loops and pedestals will be provided by you or your contractor.
- You or your electrician must submit to FEC a state electrical inspection permit.
- There will be a separate charge for temporary services.
- Your temporary service should only be located adjacent to a transformer and have enough wire stubbed out to connect directly to our facilities. If an existing transformer is not in the area, temporary service may not be available at your location. Consult FEC for other options.
- The costs for permanent services replacing temporaries will be treated as new services.

INSPECTIONS AND CODES

This handbook should be used only as a guide. It does not cover all federal, state, and local code requirements. It is your responsibility to ensure that your project complies with the most recent issues of the NEC and any other federal, state, or local codes that apply.

Once your service equipment is installed, the state, or the city with jurisdiction, requires that the installation pass an electrical inspection before we can connect you to our system. You are responsible for requesting and passing this inspection. Check your local phone book for the applicable inspection agency.

EMERGENCY OR STANDBY GENERATORS

You may elect to install an emergency or standby generator when you build your home. Permanently installed generators are to be connected to your wiring system by a permanently installed transfer switch intended for that purpose. The transfer switch is used to disconnect all ungrounded conductors connected to FEC’s system prior to connecting the generator to the conductors supplying your home. The transfer switch is to be designed and installed so that the generator cannot be connected to FEC’s system in any mode of operation. When the switch is in the position that disconnects FEC’s service, it must have a visible opening and be lockable in that position. Compliance with these provisions is necessary to prevent serious or possible fatal accidents to FEC line personnel.

Portable generators shall not be connected through your house wiring system at any time unless the connection is made through a permanently installed transfer switch.

All transfer switches and/or transfer operating schemes must meet applicable building codes and be inspected by the appropriate governmental electrical inspector. FEC will require an inspection be made by FEC personnel prior to operation of the generator.

For more detailed information contact FEC and request our “Safely Installing Your Standby Electric Generator” pamphlet.

OVERHEAD SERVICE

GENERAL REQUIREMENTS

If you wish to have an overhead service to your home, the information in this section will help you. The following is a checklist that will assist you in preparing your project for the installation of your overhead service. After you have completed these items, FEC will install your service line and meter.

- Make sure you're in an overhead area.
- Check to see if any local ordinances or covenants prevent you from installing an overhead service.
- Apply for the city or state electrical inspection.
- Determine an acceptable location for your meter base. See page 9.
- Install your service equipment.
- Install your service entrance conductors. (leave 2 feet exposed at the weatherhead)
- Verify that the service mast height requirements have been met.

GETTING STARTED

The first step when installing new overhead service is to determine which power pole your service will be taken from. If you have trouble determining which pole you will be taking service from contact FEC.

Next, determine the location of the meter base. The meter base shall be located outside in an area that is accessible to FEC personnel at all times. If the service line will be passing through any trees, you must provide and maintain a clear path for the overhead service lines.

Another factor to consider when choosing the location for the meter base is what types of terrain the service line will be crossing. FEC suggests, whenever possible, that you avoid service line routes that will cross a driveway. Service lines crossing driveways can be hit by vehicles and cause damage to service equipment, and even to the home. See Figure 1-6 for a typical overhead service installation.

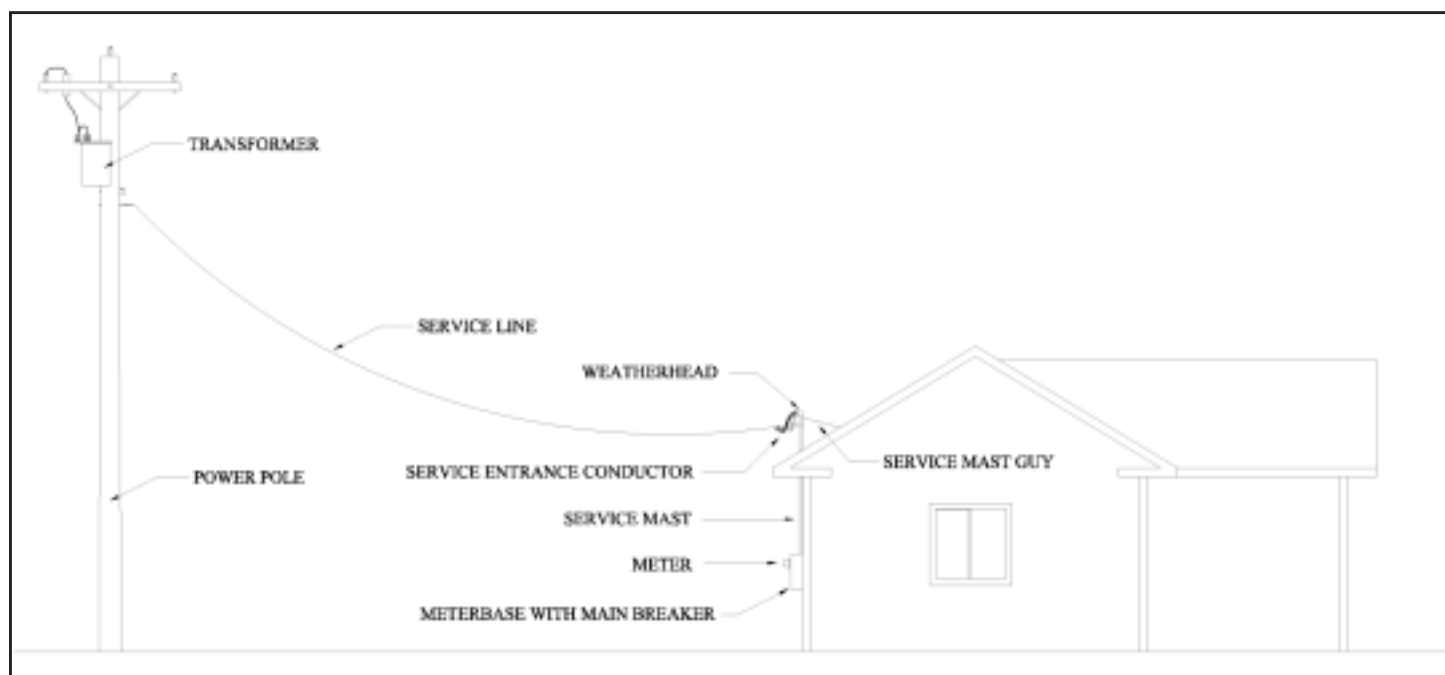

Figure 1-6. Typical overhead service installation.

SERVICE MAST REQUIREMENTS

A service mast is a conduit that runs vertically from the top of the meter base up through your roof. It contains service entrance conductors and typically supports one end of your service line. Service masts are necessary when installing an overhead service, and are installed by you or your electrical contractor. The service mast must be rigid aluminum or steel conduit. FEC will supply a service mast wire holder which provides the connection between your service mast and our service wire.

The requirements for the installation of your service mast are covered in the NEC. Some of the more common methods are included in this section for your information.

HEIGHT REQUIREMENTS

The top of a service mast must be at least 13 feet above final grade so that the clearances over your property can be maintained. Additional height may be required depending upon the location and type of structure or terrain your service line passes over. Figure 1-7 illustrates some of the minimum clearances that must be maintained.

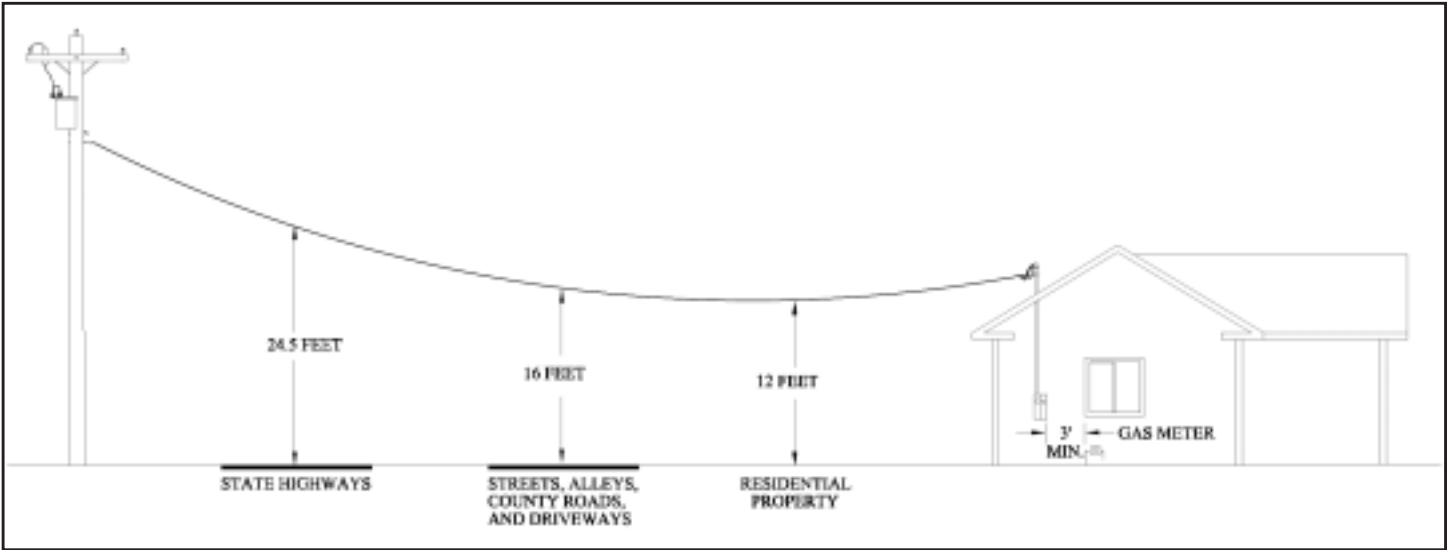

Figure 1-7. Minimum clearances from ground.

The NEC also requires that the service mast maintain minimum clearances above your roof. The clearance required depends upon the slope of your roof, and whether or not the service line is attached to the structure.

Figure 1-8 is one example of a service mast installation with the service line attached to the mast. This is the method preferred by FEC. For other options and details consult the NEC.

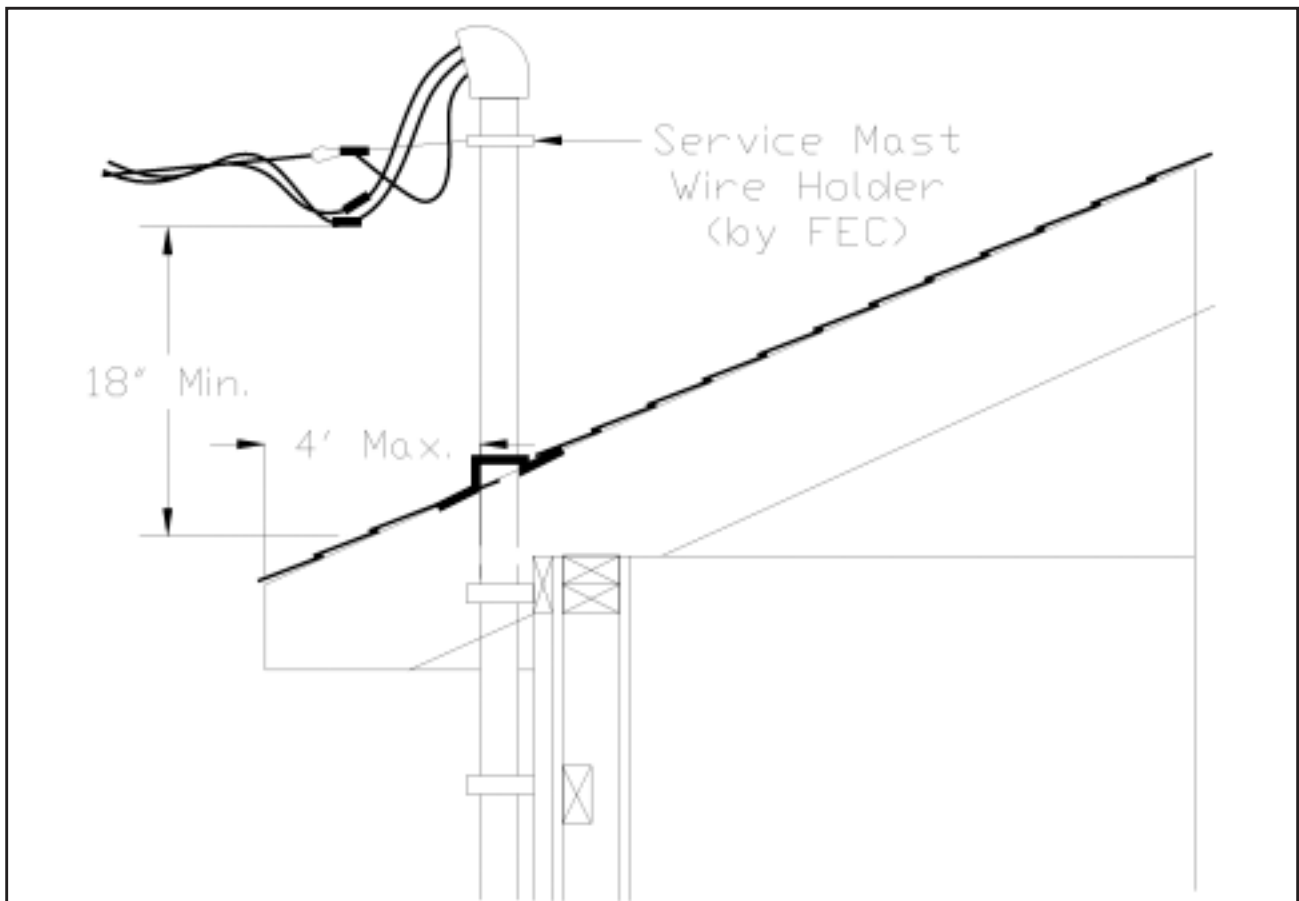

Figure 1-8. Service mast clearance example.

Service lines passing over the roof of another structure or decks must maintain the minimum clearances shown in Figure 1-9. If you have questions about the proper mast height, please call us and we will assist you.

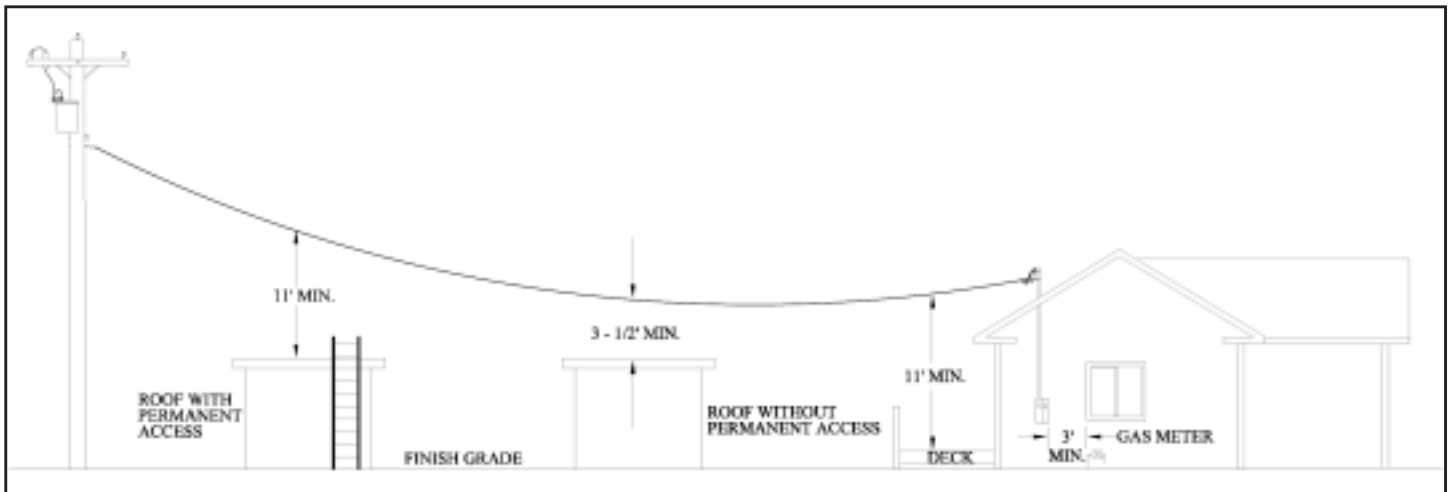

Figure 1-9. Minimum vertical clearances over other structures.

ADDITIONAL MAST SUPPORTS

Additional mast supports, typically a guy or a brace, are required for any service line over 100 feet in length. Guys and braces are installed to prevent the weight of the service line from pulling the service mast away from your home. Further information regarding guying and bracing service masts is available in the NEC.

Additional mast supports are required when:

- The service line is over 100 feet long.
- The top of the service mast is more than 26 inches above the roof.

See Figure 1-10 for an example of a service mast guy.

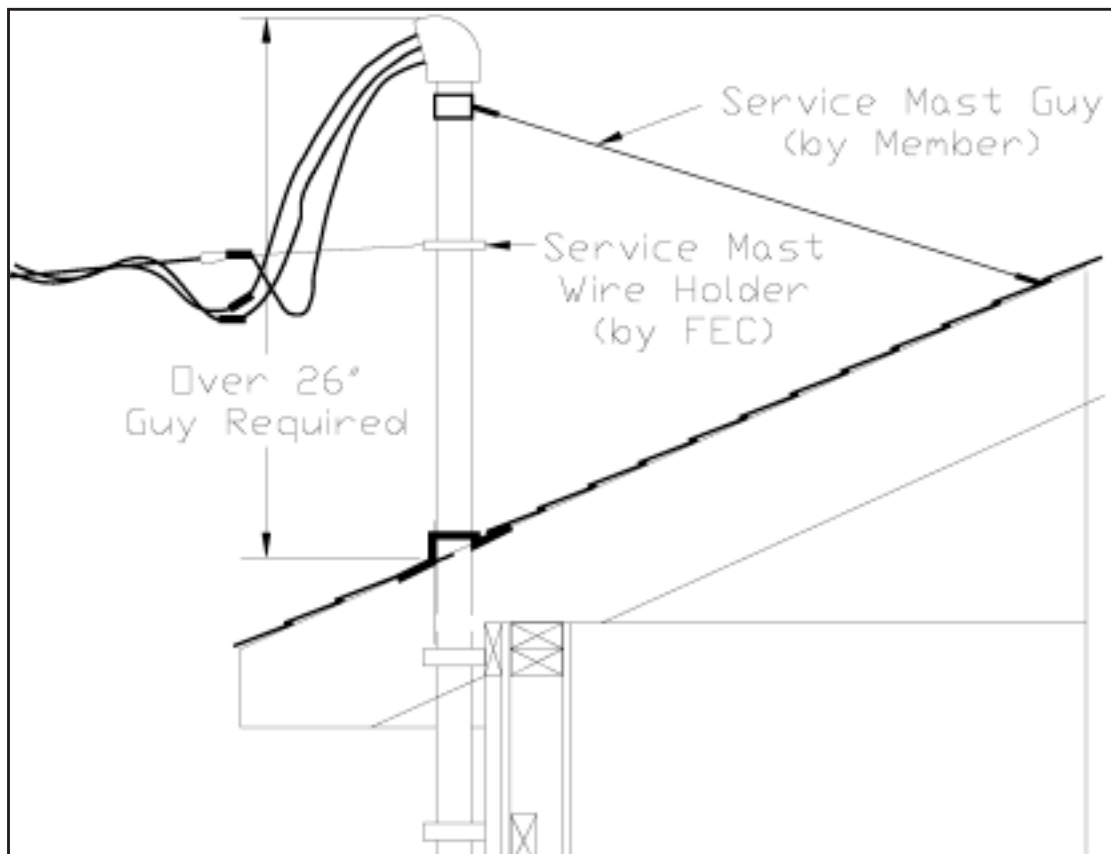

Figure 1-10. Service mast guying.

SERVICE EQUIPMENT INSTALLATION REQUIREMENTS

After determining the meter base location, the service route, the height of your service mast, and the size of your service equipment (200 amp, 320 amp, etc.), you are ready to begin installing your service equipment. **Remember, FEC allows only surface mounted meter bases.**

Once you have installed the meter base and mast, you are ready to provide and install your service entrance conductor. The service entrance conductor is the wiring that is connected to the top lugs in your meter base and runs upward through the service mast. The service entrance conductors must be

sized according to the NEC and to the rating of your meter base. When installing the wire, leave at least 2 feet of wire exposed at the end of the weatherhead to allow FEC to connect the service line to your wire. When you install your meter base, make sure the center of the meter will be between 4.5 and 6 feet above finished ground level.

If you have any questions regarding the installation of your service equipment we suggest that you consult the NEC or contact an electrical inspector. See figure 1-11 for an example of a surface mounted meter socket.

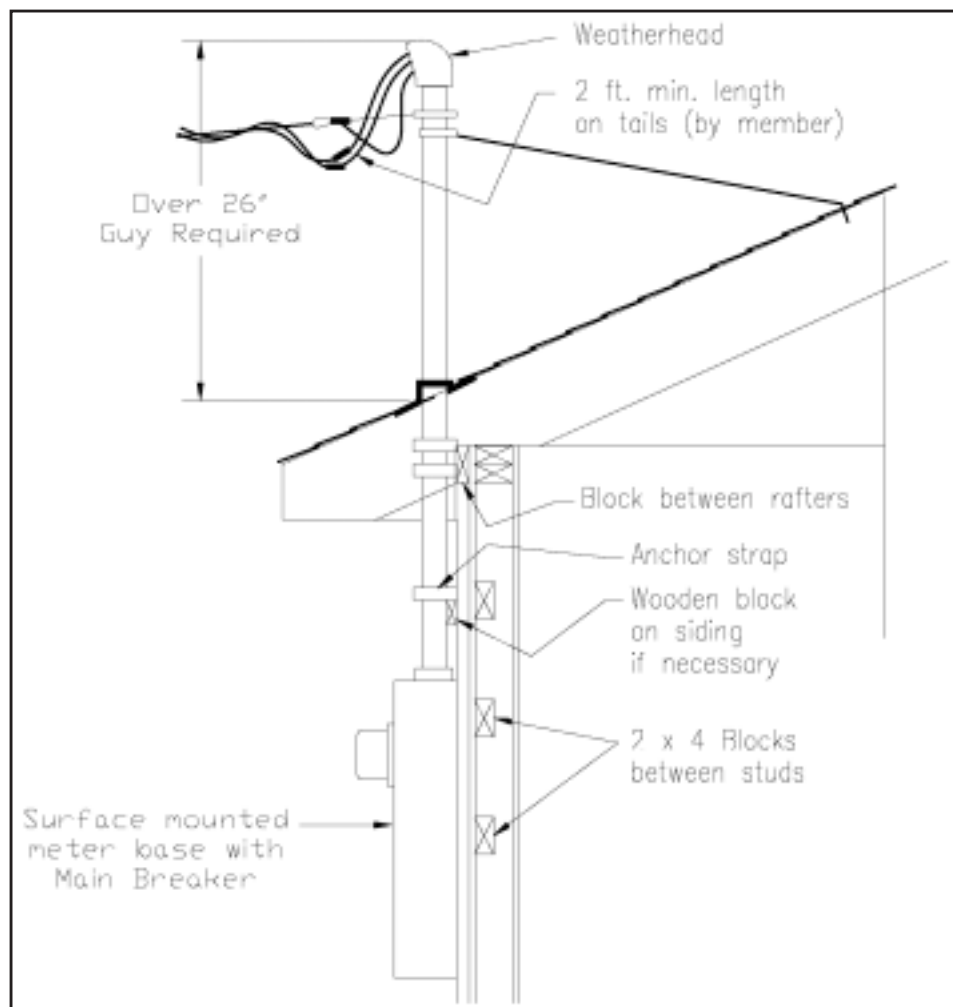

Figure 1-11. Surface mounted meter socket.

MANUFACTURED HOMES

When installing overhead service to a manufactured home, service equipment can be installed one of two ways:

1. On a meter pole.

Or if the manufactured home is on a permanent foundation

2. On the manufactured home, if one of the following conditions is met

- a. The manufacturer installed the service equipment at the time the home was built.
- b. The service equipment meets the meter base requirements listed as follows:

Meter bases installed on manufactured homes must:

- Be located on an outside wall of the home
- Be between 4.5 and 6 feet above finished grade.
- Not be in a walkway, breezeway or carport.
- Not be in an area that is subject to being fenced or where decking or foliage will block easy access to it.
- Have a service mast that is at least 13 feet above finished grade. See the height requirements section on pages 6 and 7.

If the home manufacturer did not install service equipment on the home when it was built, you must get approval from the local electrical inspection agency before you install a meter base on your manufactured home. Figure 1-11a (Appendix, page 20) shows an example of a typical surface mounted meter socket.

METER POLES

If a meter pole is required for your project, FEC will provide the pole, and if required, a guy and anchor. See Figure 1-12 for an example of a meter pole installation. The meter pole will have the same location requirements as discussed previously for meter bases located on the outside of a house. See page 9 for more details. Typically the meter pole will be installed within 30 feet of the home. Figure 1-12a (Appendix, page 20) shows a typical meter pole.

- ▲ **Items owned and installed by FEC**
 1. Fully treated service pole
 2. Service line
 3. Down guy (when required)
 4. Meter
 5. Insulated Clevis
 6. Anchor (when required)
- **Items owned and assembled by member**
 7. Meter base with disconnect switch and 10' or 15' mast
 8. Service entrance conductors – 2 feet out of weatherhead
 9. Service entrance conduit in accordance with NEC
 10. Ground wire in accordance with NEC
 11. Multiple 8' Ground rods in accordance with NEC
 12. Customer owned service wire to house

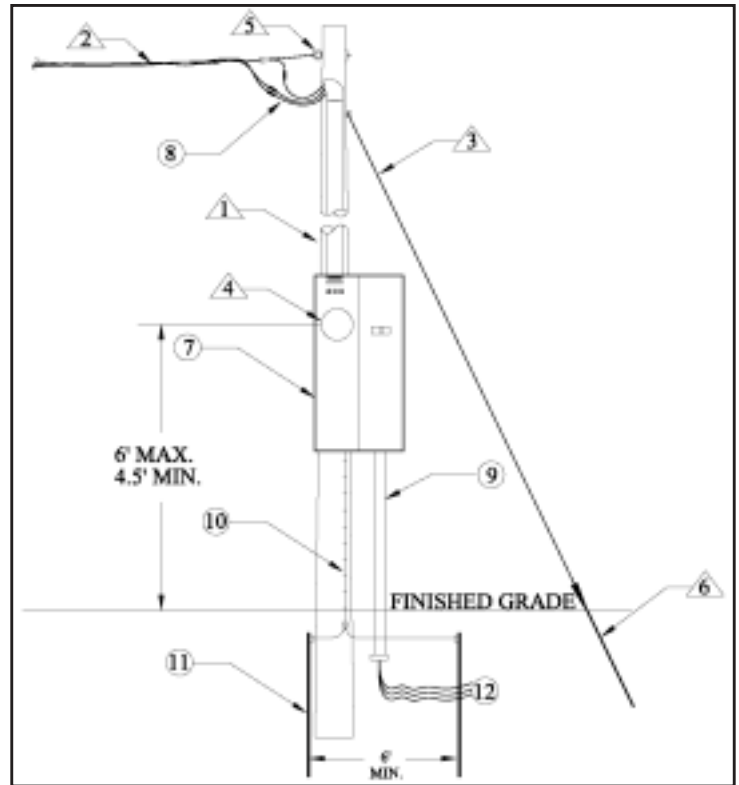

Figure 1-12 FEC owned meter pole.

100/200 AMP OVERHEAD SERVICE METER BASE REQUIREMENTS

The 120/240 volt, 100 and 200 ampere services are the most common services, and are typically installed on homes with a living space of less than 2500 square feet. However, it is your responsibility to determine the electrical requirements and to notify FEC of the size service you would like. Meter bases for 100 or 200 amp overhead services must:

- Be UL (Underwriters Laboratory) approved.
- Be rated for exterior use, and be rain tight according to NEMA-3R. **(FEC will not accept flush or semi-flush meter base installations)**
- Be protected from ice, snow and debris unloading from the roof.
- Have all unused openings tightly sealed from the inside of the base.
- Must be plumb and securely fastened to the supporting structure.
- Have a main disconnect.
- Only ring type meter sockets are acceptable. Ring-less meter sockets shall not be used.
- Be rated for 120/240 volts and 100 or 200 amps.
- Contain four meter jaws and one connection point for the neutral conductor.

320 AMP SERVICE METER BASE REQUIREMENTS

The meter base required for a 120/240 volt, 400 ampere service is called a “Class 320” meter base. It is larger than the 200 amp meter base, but it is still a self-contained meter base (it doesn’t require current transformers). It can be installed on residences where your continuous current rating is 320 amps or less. Meter bases for 320 amp overhead service must:

- Be UL (Underwriters Laboratory) approved.
- Be rated for exterior use, and be rain tight according to NEMA-3R. **(FEC will not accept flush or semi-flush meter base installations)**
- Be protected from ice, snow and debris unloading from the roof.
- Have all unused openings tightly sealed from the inside of the base.
- Must be plumb and securely fastened to the supporting structure.
- Have a main disconnect.
- Only ring type meter sockets are acceptable. Ring-less meter sockets shall not be used.
- Be rated for 120/240 volts and 320 amps continuous.
- Contain four meter jaws and one connection point for the neutral conductor.
- Contain provisions for the installation of Class 320 meter.

SERVICES 400 AMPS AND ABOVE

120/240 volt services 400 amps and above require CT metering. Please refer to the FEC *Electric Service Requirements Handbook*.

GROUNDING REQUIREMENTS

All meter bases, enclosures, and conduit must be bonded and grounded in accordance with the NEC. If you elect to use a "UFER" ground installation that is poured into the footing of your structure, FEC will require that you provide an inspection certificate from your electrical inspector verifying that the re-bar and ground were properly installed in the foundation. If you elect to use driven ground rods, FEC will require that you install two 8' long rods spaced 6' apart and bonded together.

CLEARANCES FROM BUILDING OPENINGS AND GAS METERS

A minimum clearance of three feet is required between service lines and windows, doors, porches, fire escapes, or similar openings. A minimum horizontal clearance of 3 feet is required between electric service equipment and natural gas metering equipment. See Figure 1-13.

CLEARANCE REQUIREMENTS

The following clearances are required around all meter installations. It is your responsibility to provide and maintain these clearances.

- The center of the meter must be between 4.5 and 6 feet above finished grade.
- A working space of 36 inches wide by 36 inches deep is required around the meter. See Figure 1-13. This working space is to be kept clear of any obstructions including landscaping.
- There must be a minimum horizontal clearance of 3 feet between the center of the electric meter and gas meters.

Outbuildings

Meter bases for 100 to 320 amp overhead services to outbuildings that will be used for personal use (for example, garages, shops, single family wells, noncommercial barns) must meet all the requirements listed above.

However, if the outbuilding will be used for commercial or multifamily purposes (for example, a professional shop, dairy barn, multifamily/community well) you will have additional requirements, including manual bypass provisions. If this is the case, please refer to the FEC *Electric Service Requirements Handbook*.

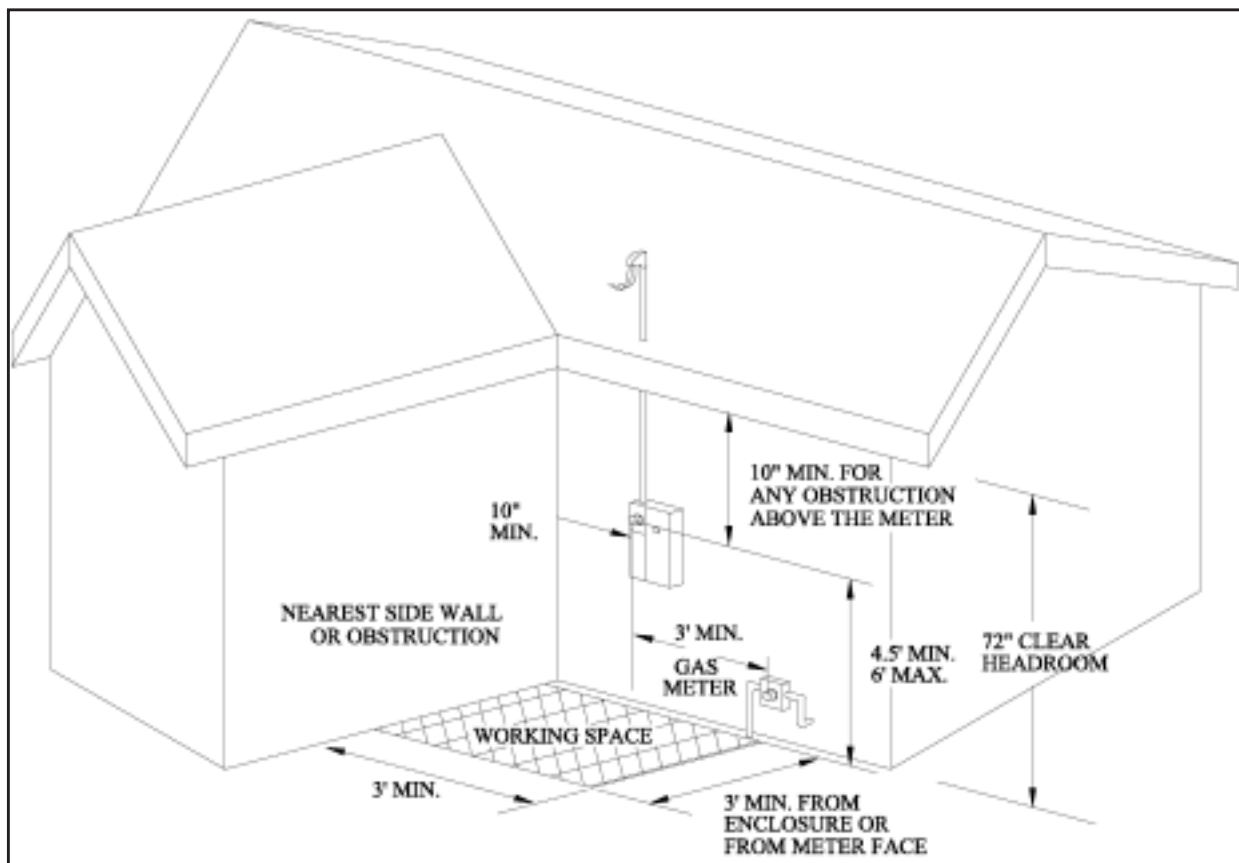

Figure 1-13. Meter socket minimum clearances.

UNDERGROUND SERVICE

GENERAL REQUIREMENTS

If you wish to have an underground service to your home, the information in this section will help you. The following is a checklist, which should be used as a guide to assist you in preparing your project for the installation of your underground service. Once you have completed these items, FEC will install your service line and meter.

- Apply for the city or state electrical permit.
- Determine an acceptable location for your meter base. See page 9.
- Provide a trench and conduit from the meter base to the location where the service line will originate.
- Install your service equipment.

See figure 1-14 for an example of a typical underground installation.

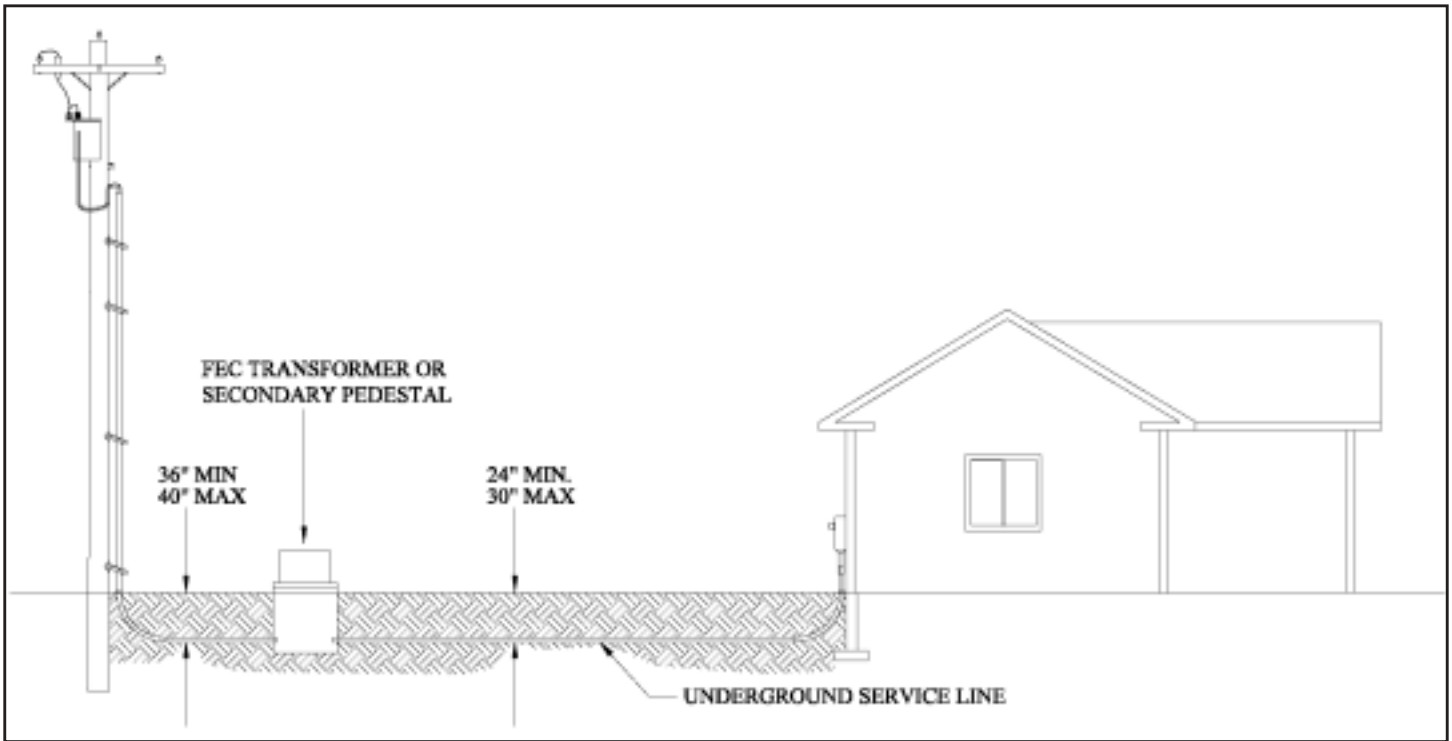

Figure 1-14. Typical underground installation.

SERVICE EQUIPMENT INSTALLATION REQUIREMENTS

After determining the meter base location, the service route, and the size of your service equipment (200 amp, 320 amp, etc.), you are ready to begin installing your service equipment.

FEC only allows surface mounted meter bases. When you install your meter base, make sure the center of the meter will be between 4.5 and 6 feet above finished ground level. In addition make sure you have installed the correct slip joint in the service entrance conduit. See Figure 1-15 for a typical surface mounted meter socket.

The size of service determines the options for the size of the service entrance conduit. The options for the various sizes are:

SERVICE SIZE CONDUIT REQUIREMENT

0-125 Amps	2-inch Schedule 40 gray PVC conduit.
200-320 Amps	3-inch Schedule 40 gray PVC conduit.
400 Amps and above	Contact Flathead Electric Coop

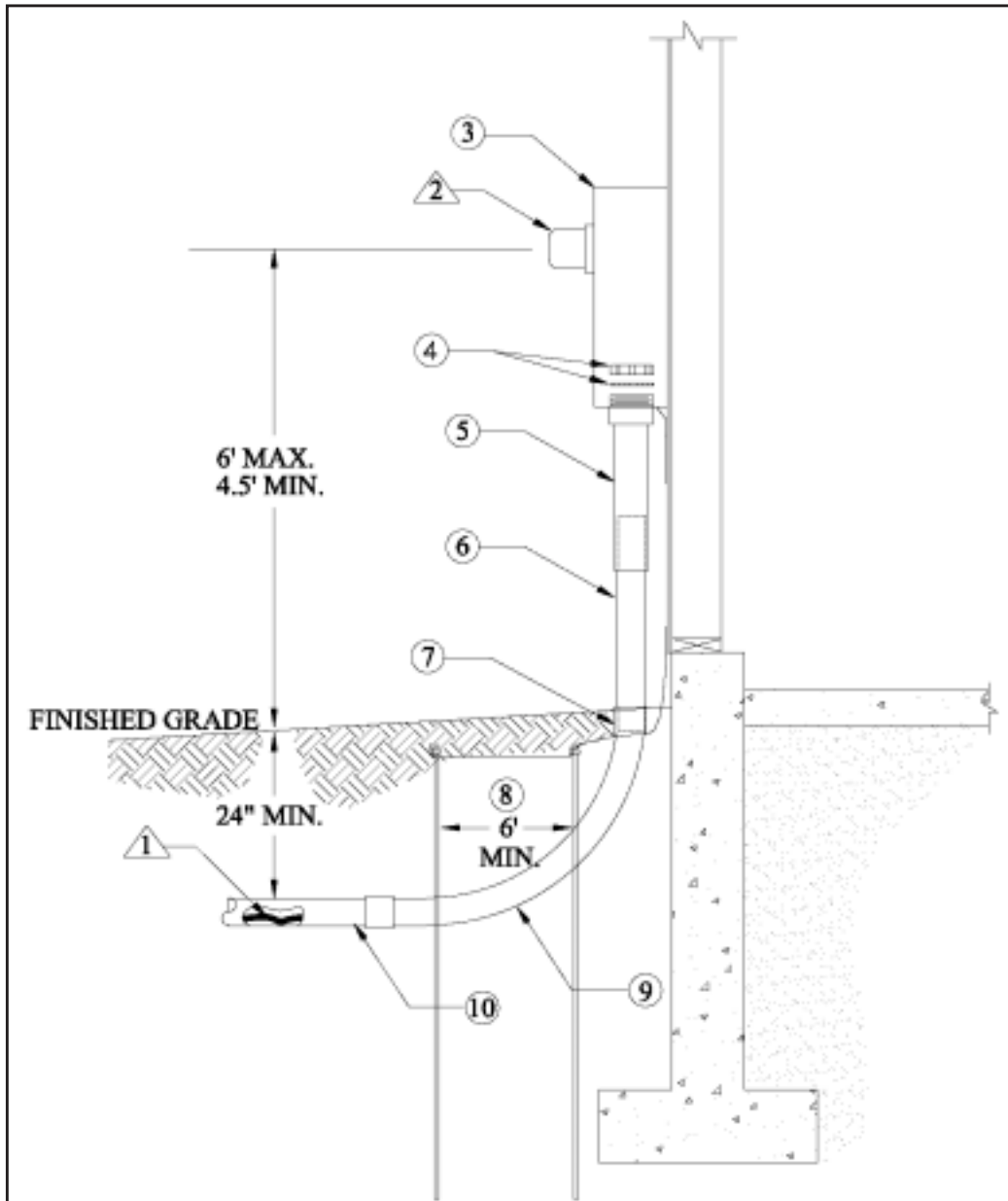

Figure 1-15. Surface mounted meter socket.

▲ ITEMS OWNED AND INSTALLED BY FEC

- 1. Service line
- 2. Meter

○ ITEMS OWNED AND INSTALLED BY MEMBER

- 3. Meter base with disconnect switch
- 4. Insulating bushing and locknut
- 5. Slip Joint
- 6. Service Entrance Conduit as specified on page 17
- 7. Ground wire in accordance with NEC
- 8. Multiple 8' Ground rods in accordance with NEC
- 9. Wide radius sweep
- 10. Conduit installed per FEC Specifications

Figure 1-15a (Appendix, page 20) shows a typical 200 amp surface mounted meter socket and Figure 1-15b (Appendix, page 20) shows a typical 320 amp surface mounted meter socket.

▲ **Items owned and installed by FEC**

1. Service line
2. Meter

○ **Items owned and installed by member**

3. Meter base with disconnect switch
4. Ground wire in accordance with NEC
5. Multiple 8' Ground rods in accordance with NEC
6. Wide radius sweep
7. Conduit installed per FEC Specifications
8. Customer owned service wire to house

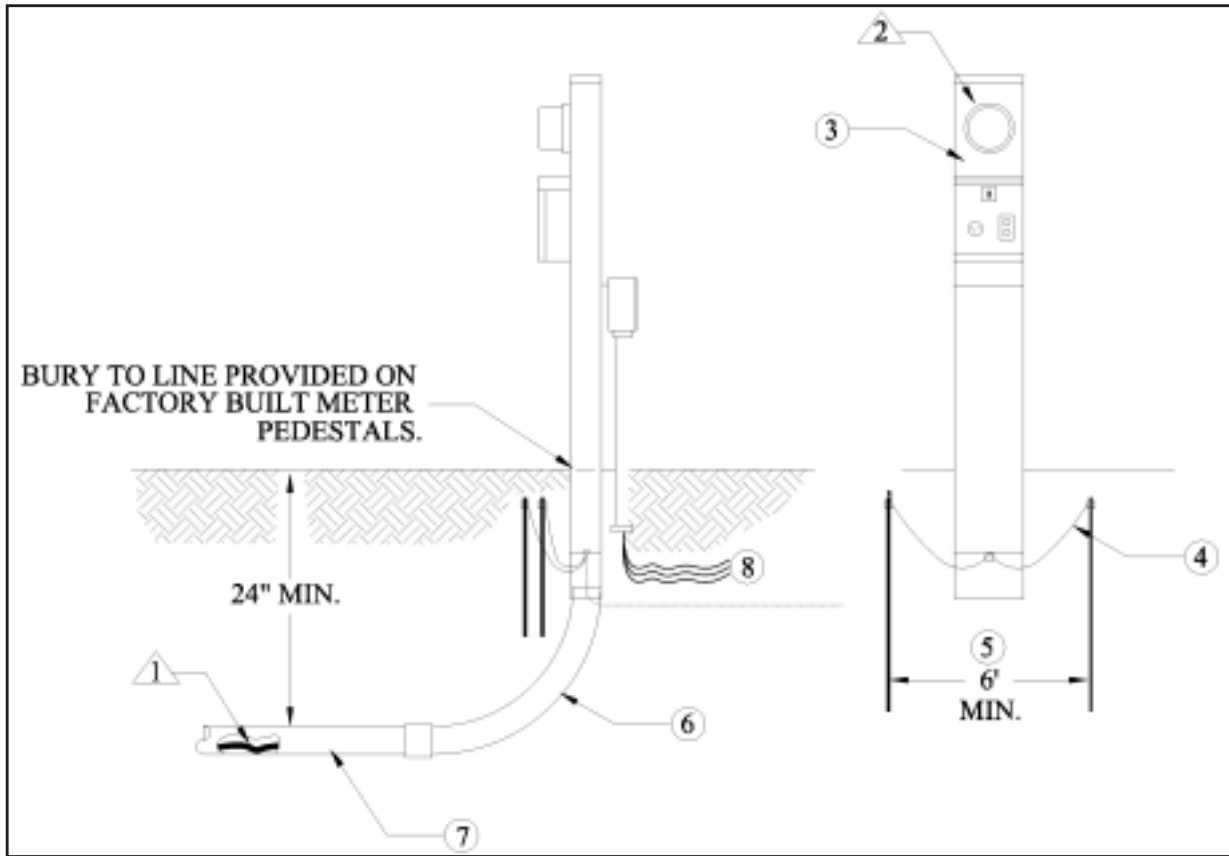

Figure 1-17. Factory built meter pedestal.

100/200 AMP SERVICE

SINGLE FAMILY RESIDENTIAL

The 120/240 volt, 100/200 ampere service is the most common service, and is typically installed on homes with a living space of less than 2500 square feet. However, it is your responsibility to determine the electrical requirements and to notify FEC of the size service you would like. Meter bases for 100 or 200 amp underground services must:

- Be UL (Underwriters Laboratory) approved.
- Be rated for exterior use, and be rain tight according to NEMA-3R. **(FEC will not accept flush or semi-flush meter base installations)**
- Be protected from ice, snow and debris unloading from the roof.
- Have all unused openings tightly sealed from the inside of the base.

- Must be plumb and securely fastened to the supporting structure.
- Have a main disconnect.
- Have a ring type meter socket. Ring-less meter sockets are not acceptable.
- Be rated for 120/240 volts and 100 or 200 amps.
- Contain four meter jaws and one connection point for the neutral conductor.

The center knockout should not be used on an underground meter base because of the bending radius of the cable.

320 AMP SERVICE

The meter base required for a 120/240 volt, 400 ampere service is called a “Class 320” meter base. It is larger than the 200 amp meter base, but it is still a self-contained meter base (it doesn’t require current transformers). It can be installed on residences where your continuous current rating is 320 amps or less. If your structure will require more than 320 amps continuous, you may be required to install a current transformer (CT) service. Please contact us to discuss your power requirements and get more information regarding services above 320 amps. Meter bases for 320 amp underground services must:

- Be UL (Underwriters Laboratory) approved.
- Be rated for exterior use, and be rain tight according to NEMA-3R. **(FEC will not accept flush or semi-flush meter base installations)**
- Be protected from ice, snow and debris unloading from the roof.
- Have all unused openings tightly sealed from the inside of the base.
- Must be plumb and securely fastened to the supporting structure.
- Have a main disconnect(s).
- Only ring type meter sockets are acceptable. Ring-less meter sockets shall not be used.
- Be rated for 120/ 240 volts and 320 amps continuous.
- Contain four meter jaws and one connection point for the neutral conductor.
- Contain provisions for the installation of Class 320 meter.
- Have lugs that will accept 350 MCM aluminum wire.
- Have at least 8-1/2 inches of clearance between the bottom of the lugs and the bottom of the enclosure.

SERVICES 400 AMPS AND ABOVE

120/240 volt services over 400 amps and above require CT metering. Please refer to the FEC *Electric Service Requirements Handbook*.

GROUNDING REQUIREMENTS

All meter bases, enclosures, and conduit must be bonded and grounded in accordance with the NEC. If you elect to use a “UFER” ground installation that is poured into the footing of your structure, FEC will require that you provide an inspection certificate from your electrical inspector verifying that the re-bar and ground were properly installed in the foundation. If you elect to use driven ground rods, FEC will require that you install two 8’ long rods spaced 6’ apart and bonded together.

CLEARANCE REQUIREMENTS

The following clearances are required around all meter installations. It is your responsibility to provide and maintain these clearances.

- The center of the meter must be between 4.5 and 6 feet above finished grade (except meter pedestals).
- A working space of 36 inches wide by 36 inches deep is required around the meter. See Figure 1-18. This working space is to be kept clear of any obstructions including landscaping.
- There must be a minimum horizontal clearance of 3 feet between the center of the electric meter and gas meters.

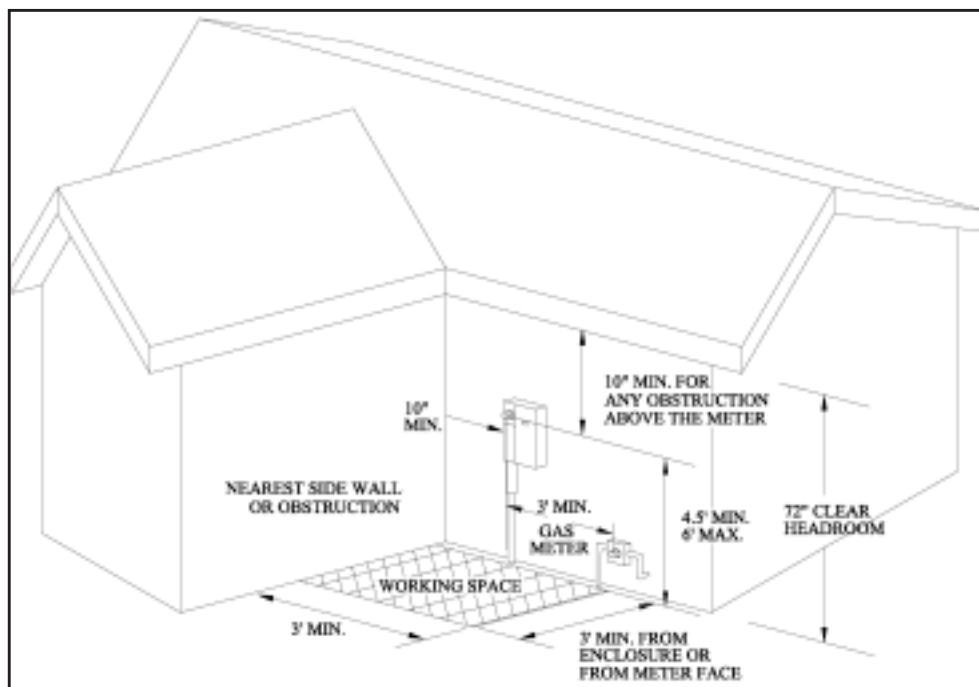

Figure 1-18. Meter socket minimum clearances.

OUTBUILDINGS

Meter bases for 100 to 320 amp services to outbuildings that will be used for personal use (for example, garages, shops, single family wells, noncommercial barns) must meet all the requirements listed above.

However, if the outbuilding will be used for commercial or multifamily purposes (for example, a professional shop, dairy barn, multifamily/community well) you will have additional requirements, including manual bypass provisions. If this is the case, please refer to the FEC *Electric Service Requirements Handbook*.

UNDERGROUND LOCATES

If you are doing any trenching or excavation work, you are required to call for underground utility locates at least two working days before you do any digging.

You can get underground utility locates by calling “U-Dig” locally at (406) 755-8344 or at 1-800-551-8344. There is no charge for this service. More information about “U-Dig” can be found on their web site at www.udig.org.

Once you have called and requested a locate, U-Dig will notify the utilities, or a locating service, that locates are required. However in some areas, not all utilities are members of the One Call system. In those areas you must contact the utilities individually.

The state has established a color code system to identify each utility so everyone can see what has been located. The color codes are:

Color	Utility
Red	Electric
Yellow	Gas/Oil/Steam
Orange	Telephone/Cable TV
Blue	Water
Green	Sewer
Pink	Temporary Survey Markings
White	Area to be located

Any digging within 24 inches of either side of the location markings must be done by hand.

TRENCH, CONDUITS AND VAULTS

The purpose of this section is to clearly outline the requirements for the installation of vaults and conduits used in the FEC electrical distribution system. FEC requires all new underground line extensions to install a conduit and vault system. All guidelines in this section must be followed. Any deviation from these requirements must be approved by FEC prior to construction. Failure to do so may result in the rejection of the installation. If there are any questions please contact FEC’s Staking Department.

TRENCH

Preparation

- Know whose property you are on! Be sure you have the legal right to dig on the property. FEC will not install electric lines on property where we do not have the consent of the owner.
- If you are digging in the Montana Department of Transportation (MDOT) right of way you must obtain a copy of the MDOT 131 permit from FEC. You must have this copy on site while the trenching is being done. Failure to do so could result in the state taking action against you.
- After the trench route has been determined you must have all underground utility lines located. This service is free of charge. In the Kalispell area call 775-UDIG (755-8344) two working days before you dig so these lines can be located. Remember the locate marks are only accurate to within 18”.

General

- The bottom of the trench must be smooth and level. This prevents ‘bridging’ of the conduit, which can cause the conduit to flatten or pull apart when the trench is backfilled.
- The trench must be free of sharp rocks, concrete waste and other construction debris. In extremely rocky areas sand bedding may be required.
- The trench must be a minimum of 5 feet from septic tanks and a minimum of 10 feet from a drain field.
- FEC requires inspection of primary trenches and conduit installations prior to backfilling.

Width and Depth

- There are two different trench specifications. The first is the primary trench. The primary is the main line that goes from vault to vault or pole to vault.
- The proper dimension for a primary trench is 18” wide and 36” to 40” deep.
- The second is the secondary trench. The secondary is the line that goes from the transformer to the meter.
- The proper dimension for a secondary trench is 18” wide and 24” to 30” deep.

CONDUITS

Installation

- All conduits will be installed in a trench with a level bottom to avoid a ‘bridging affect’.
- Keep the inside of the conduit clean and free of any foreign materials.
- When gluing the conduit the use of a primer is recommended. Be careful not to get excess glue inside the conduit.
- Special care needs to be taken to avoid blocking other conduit knock outs on the vault and any other utilities conduit or direct bury line.
- Conduits installed in vaults should only extend 2” to 4” into the vaults. The conduits should enter the vaults as straight as possible.
- A 1/4” nylon pull rope will be installed in all conduit runs.

Specifications

- Conduit size and number of conduits will be determined by the FEC Engineering Department. Be sure you know what size and how many conduits are required for your installation. If you use too small or too few conduits your system will be rejected.
- Buried conduits will be Schedule 40 gray electrical P.V.C.
- Any exposed conduits (going into meter bases etc.) must be Schedule 80 gray electrical P.V.C.

Sweeps

- All sweeps used must be long radius sweeps. In conduit runs less than 200' and 270° of bend P.V.C. sweeps can be used. Conduit runs greater than 200' or 270° of bend must use steel or burn proof fiberglass long radius sweeps.
- Heating and bending of conduits will be allowed but MUST be inspected by FEC before backfilling. Be careful not to flatten the conduit when bending. This decreases the ability to pull our lines through the conduit at that point.

VAULTS

General

- There are two standard vault sizes (single phase and three phase) that may be required for underground line extensions. The engineer will determine which will be used for your application. These vaults are produced to FEC specifications and vaults will not be accepted from manufacturers without prior approval from FEC. FEC's vault specifications are available upon request. The manufacturers listed below are currently producing approved vaults:

FLATHEAD CONCRETE PRODUCTS (406) 752-4259
GLACIER PRE-CAST CONCRETE (406) 752-7163
GRANITE CONCRETE (LIBBY) (406) 293-3777

- Some applications may require 'specialty' vaults. The specifications for the 'specialty' vaults will be provided by FEC.
- **FEC reserves the right to reject any vault that does not comply with FEC specifications.**

Vault Location

- Vaults will be placed according to the design provided by the FEC engineering department. Any variation from the design MUST be approved by FEC prior to construction. Failure to follow these steps may result in

the rejection of the installation.

- A minimum clear zone of 10' from the centerline of the vault must be maintained in order for FEC to place and work on our equipment. Access to all vault locations must be maintained for maintenance and future line extensions. All vault locations must be accessible by a boom truck at the time of installation and in the future.
- Vaults will also need to be located to maintain the following minimum clearances as listed below:

3 ft. - from noncombustible walls (including brick, concrete, steel and stone), provided the side of the wall facing the transformer does not have a door.

10 ft. - from combustible walls (including stucco), doors, windows, vents, fire escapes, and other building openings.

15 ft. - from the water's edge of a swimming pool or any body of water.

20 ft. - from facilities used to dispense or store hazardous liquids or gasses such as gas tanks, propane tanks, gas pumps, etc.

Clearances between vaults and structures must be measured from the point of the vault nearest to the building or structure. These clearances include any overhangs on buildings. If you have any questions regarding the installation of your service equipment we suggest that you consult the NEC, call the inspecting agency for your area, or contact an electrical contractor. **Remember: Call "U-Dig" before digging.**

Setting the Vault

- All vaults will be set level. This is best accomplished by setting the vault on 4" of pea gravel. The pea gravel also aids in draining any water from the vault.
- Vaults will be set at a depth where the vault (without the lid) is 2" to 4" above final grade. This prevents water and dirt from entering the vault.
- The orientation of the vault should be such that the copper wire that exits the concrete (UFER Ground) is in the back.
- The floor drain that is located in the bottom of the vault should be knocked out except in areas with a high water table.
- Holes that have been enlarged or knock outs that have been removed and not used need to be sealed with grout. Minor damage can also be repaired with grout.
- Clean out the inside of the vault after it is set. Keep all dirt and construction debris out of the vault.
- FEC retains the right to reject all vaults that are not properly installed or are damaged.
- See Figure 1-19 for a typical conduit and vault installation.

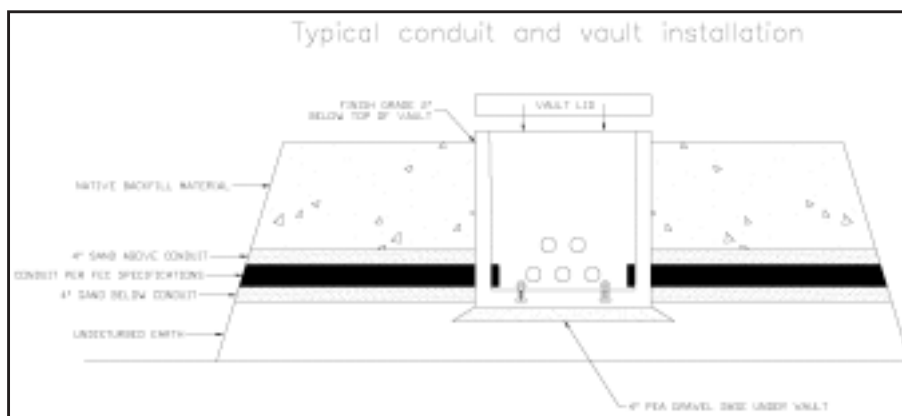

FIGURE 1-19. Typical conduit and vault installation.

SERVICE OFFICE INFORMATION

Flathead Electric Cooperative, Inc.

2510 US Highway 2 East
Kalispell, MT 59901-2397

Mailing Address

2510 US Highway 2 East
Kalispell, MT 59901-2397

FEC Website: www.flatheadelectric.com

Kalispell Headquarters

751-4483 or 1-800-735-8489 Fax: (406) 752-4283

Libby Service Center

121 West 4th Street Libby, MT 59923
(406) 293-7122 Fax: (406) 293-3821

UDIG or Call Before UDIG

755-UDIG (8344) or 1-800-551-8344
www.udig.org

MT Department of Commerce

Electrical Safety Section

1218 East 6th Avenue or P.O. Box 200517
Helena, MT 59620-0517
(406) 444-4243

Flathead County Plat Room

800 South Main Street Kalispell, MT 59901
(406) 758-5510

GLOSSARY OF TERMS

Clearance - An obstruction-free distance between two objects.

Common Ground Point - The conductor used to connect the grounding electrode to the equipment grounding conductor and/or to the grounded conductor of the circuit at the service.

Conduit - A listed or approved pipe with a smooth interior surface to permit easy drawing-in of electrical conductors. A conduit may be metallic or nonmetallic, depending on its usage, in accordance with codes and standards.

Corrosion Inhibitor - Electrical joint compound used to retard oxidation of electrical connections.

Direct Burial - The installation of electrical conductors in a trench, without the use of conduit.

Drip Loop - A loop formed in overhead secondary conductors at the weatherhead, to prevent the entrance of water into the service entrance conduit and equipment.

Electrical Inspection Agency - The qualified representative of a city, county or State of Montana, who has been authorized by governmental agencies to inspect electric service installations.

FEC - Flathead Electric Cooperative Incorporated.

Guy - A cable or brace used to relieve the strain of overhead conductors on masts and poles.

Listed - Equipment or material accepted by a nationally recognized testing laboratory, inspection agency, or other organization concerned with product evaluation.

Manual Circuit-Closing Link - A provision for paralleling the meter circuit, allowing the meter to be removed without interrupting service to the customer.

Meter Jaws - Spring-loaded receptacles inside a meter base that connect the terminals of a meter to the source and load conductors of the service.

Meter Base - The mounting device for socket-type meters, consisting of meter jaws, connectors, and an enclosure.

NEC - National Electrical Code which governs the installation of member electrical equipment.

NEMA - National Electrical Manufacturers Association.

NESC - National Electrical Safety Code which governs FEC electrical equipment.

Neutral - The grounded conductor in a single-phase, three-wire or three-phase, four-wire system. The service conductor at zero potential to ground.

Staking Department - The designated representative of FEC, responsible for coordination of new or revised services to FEC members. The Staking Department responds to inquiries on policies, standards, practices, rates and energy utilization.

Point of Attachment - The point where the FEC's service line and the customer's system are interconnected.

Seal - A locking device to secure a meter or service entrance equipment to assure safety and security.

Select Backfill - Native soil or soil brought in from another area, free from sharp objects, rocks, scrap building material, and corrosive material.

Self-Contained - In reference to meter bases: a device designed and rated to continuously carry the entire capacity of the service. The maximum self-contained meter base current rating typically used is 400 amperes (also called a single-phase Class 320 A meter).

Service Line - Conductors from FEC's system to the customer's point of delivery which can be overhead or underground.

Service Entrance Conductors - On overhead services, customer owned conductors which extend between the meter base and the point of delivery.

Service Entrance Equipment - Service conduit, conductors, weatherhead, meter base, pedestal, enclosures, service disconnect, and service panel.

Service Mast - The conduit above the meter used to provide mechanical protection for the service conductors and to support the service drop.

Temporary Service - An electrical service installed by the member and connected by FEC to provide power on a temporary basis (less than one year).

UL - Underwriters' Laboratories, a recognized test laboratory which lists materials it has tested and accepted.

APPENDIX



Figure 1-11a. Surface mounted meter socket example.



Figure 1-12a. 100/200 Amp overhead service.



Figure 1-15-a. 200 Amp surface mounted meter socket.



Figure 1-15b. 320 Amp surface mounted meter socket.



Figure 1-16a. Custom built meter pedestal example.



Figure 1-17a. Factory built meter pedestal example.